

Use the following instructions to properly install replacement wedges. Handle the new wedges with care when assembling the EXP. The Teflon<sup>®</sup> pads may become dislodged with abrupt impact.

## **EXP DISASSEMBLY**

1. Using a flat-blade screwdriver, push the ¼ turn pin in far enough to clear the opposite side of the EXP to unlock the pin.
2. With the pin still pushed past the base, turn 90° to remove the pin and spring. Remove the remaining pins and springs the same way. These will be reused.

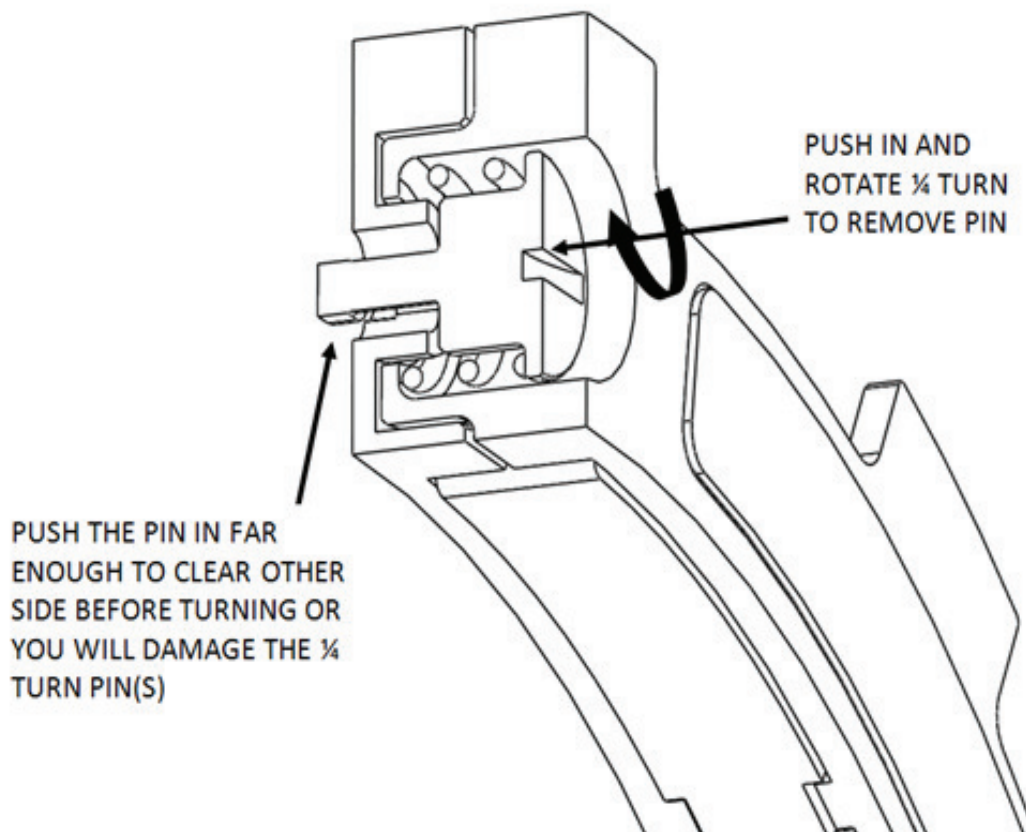

3. Separate the bases and remove the wedges. In a used EXP, be aware that Teflon pads may stick to base ramps from oil tension. Just remove the stuck pads from the EXP base before installing new wedges.

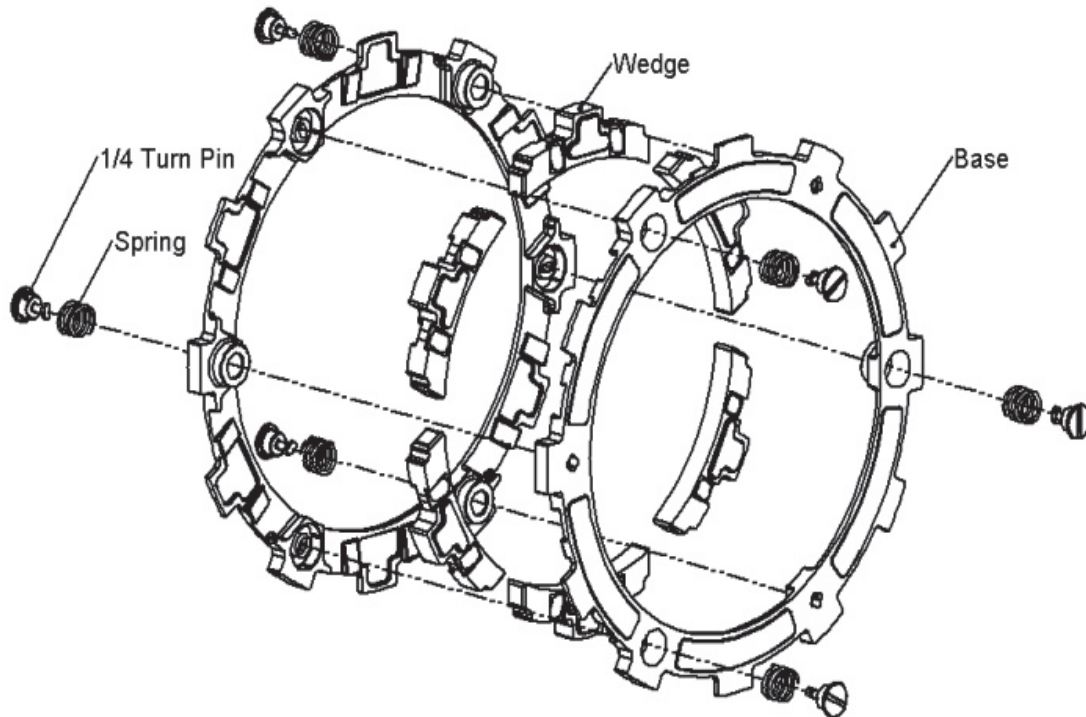

## **EXP BASE INSPECTION**

1. Clean off any debris or oil from the EXP bases with a clean shop towel.
2. Inspect the EXP bases. Pay close attention to the wedge ramps and EXP tabs. Replace the EXP bases if any damage is found.

- Tabs: Replace the EXP base if there is any evidence of hammering on the tabs.

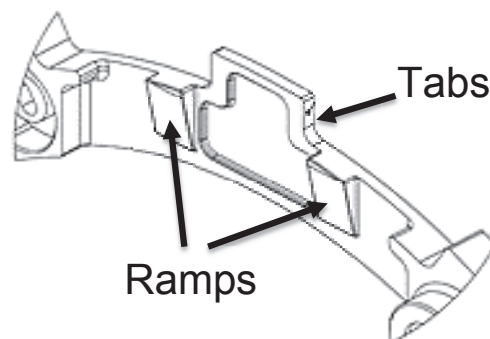

- Wedge ramps:



**Normal** - Ramps with machine marks or look shiny/polished are normal. These can be reused.

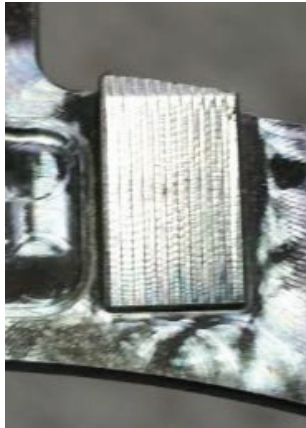

Machine marks



Shiny or polished



**Damaged** - Ramps that have a raised outline (burr) or have an indentation are damaged and need to be replaced.



Raised mark (burr)



Indentation

- **NOTE:** *It is critical that both bases are in good condition before installing new wedges. Reusing worn or damaged bases will result in poor EXP performance.*

## **WEDGE INSPECTION**

The new wedges come preassembled from Rekluse. Occasionally, a Teflon pad can fall out during shipping. If this

occurs, the pad(s) will need to be reinstalled before installing the wedges into the EXP.

1. Inspect the new wedges to make sure all the pads are still securely in the wedge pockets.
  - If any pads are loose or have fallen out, press the pad into the wedge pocket with the **flat** side of a screwdriver or similar tool.
2. Install the wedges into the EXP disk, then reinstall the EXP springs and quarter-turn pins.

**NOTE:** *The EXP disk might have a small gap down the center line once reassembled. The gap may not be even or symmetrical. This gap will close during the break-in procedure.*

3. Push each wedge out from the inside of the EXP disk to see if they move in and out. The wedges should move smoothly and spring back into place without catching.

### **BREAK IN THE NEW PADS**

1. Once the EXP is reinstalled in the clutch, set the installed gap.
2. Break in the new pads:
  - a. Shift the bike into Neutral.
  - b. With your hand off the clutch lever, rev the engine 10-15 times, being sure to let it return to idle between each rev cycle.
3. Check for Free Play Gain. Readjust the installed gap if necessary. Free Play Gain should be about 1/8" (3 mm).

### **NEED HELP?**

Visit our website at [www.rekluse.com/support](http://www.rekluse.com/support) or call us at (208) 426-0659.