

Use the following instructions to replace the Teflon pads in the EXP wedges.

EXP DISASSEMBLY

1. Use a flathead screwdriver to remove all quarter-turn pins and EXP springs (three per side). These will be reused.

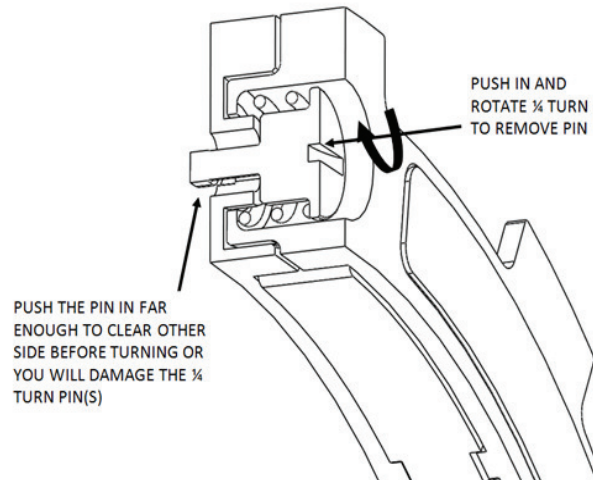

2. Separate bases and remove wedges. In a used EXP, be aware that wedge pads may stick to base ramps from oil tension. Just remove the stuck pads from the EXP base before reinstalling the wedges.

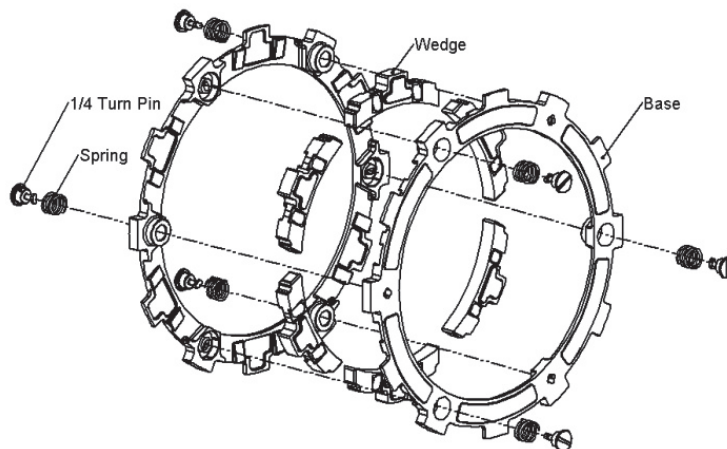

3. Inspect the EXP bases. Do not reinstall the wedges into worn bases. See the video at <https://rekluse.com/support/videos> for instructions on how to inspect the EXP disk.

REPLACE TEFLON PADS

1. Place the wedges onto a workbench.
2. Use the tip of a razor blade or knife to push into the center of the old pad, then pop the pad out.

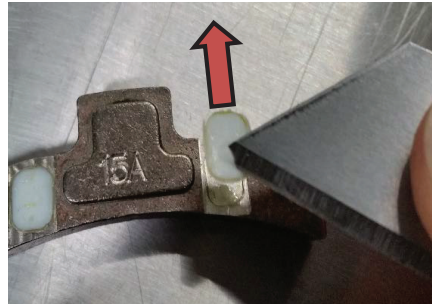
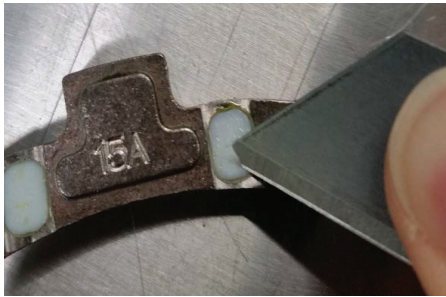

3. Place the new pad over the wedge pocket in the wedge.

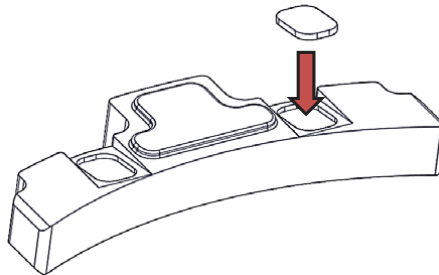

4. Use the flat part of a flat blade screwdriver or similar tool to press the Teflon pad into the wedge. You may need to turn the wedge around and press on the opposite side to get the pad to fully seat.



⚠ CAUTION

Do not press directly in the center of the pad with the tip of the screwdriver or any sharp object. This will make an indent in the pad and the wedge will not function properly.

5. Replace the other 3 pads in the same way, then finish replacing the pads on all the remaining wedges. ***When installed correctly, the pads will stick slightly above the wedge pocket.***
6. Reinstall the wedges into the EXP disk, then reinstall the EXP springs and quarter-turn pins.

NOTE: *The EXP disk might have a small gap down the center line once reassembled. The gap may not be even or symmetrical. This gap will close during the break-in procedure.*

7. Push each wedge out from the inside of the EXP disk to see if they move in and out. The wedges should move smoothly and spring back into place without catching.

BREAK IN THE NEW PADS

1. Once the EXP is reinstalled in the clutch, set the installed gap.
2. Break in the new pads:
 - a. Shift the bike into Neutral.
 - b. With your hand off the clutch lever, rev the engine 10-15 times, being sure to let it return to idle between each rev cycle.
3. Check for Free Play Gain. Readjust the installed gap until the Free Play Gain is about 1/8" (3 mm).

NEED HELP?

Visit our website at www.rekluse.com/support or call us at (208) 426-0659.