

## INSTALLATION GUIDE

1. Soak the friction disks in clean engine oil for 10-15 minutes. Make sure the friction disks are coated on both sides. *Pouring oil into the plastic bag suffices.*

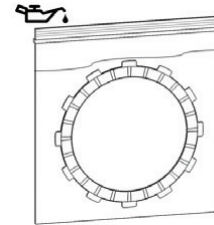

2. Remove the old clutch pack.
3. Remove the old basket sleeves and inspect the clutch basket for damper and/or spring rotational play.
  - Dampers/springs should not be loose. Inspect the clutch basket for notching. Do not install sleeves or use product with a notched basket. Notched basket tang faces can cause the sleeves to break. Do not use baskets that have been filed, machined, or modified on the tangs. Replace basket if necessary.

### ⚠ WARNING

Failure to inspect the basket and replace if necessary could result in death, serious injury, and/or property damage.

4. Install the new basket sleeves into the basket slots. Make sure the sleeve tabs sit against the inside of the basket, then push the sleeves down until they contact the bottom of the tang slot.

Install all the  
basket sleeves

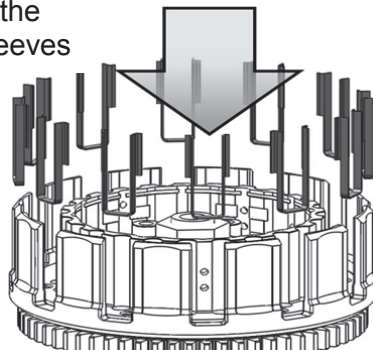

SLEEVE TOP MAY BE  
ABOVE OR BELOW  
BASKET TANG

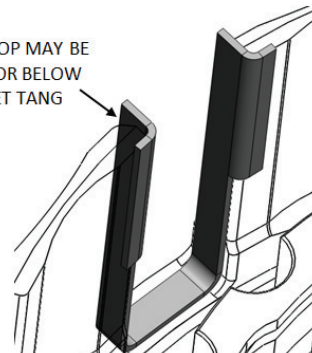

5. Install the clutch pack by **starting with a steel drive plate**.
6. Add a friction disk, then continue to alternate steel drive plates with friction disks for the entire clutch pack, ending with a friction disk.

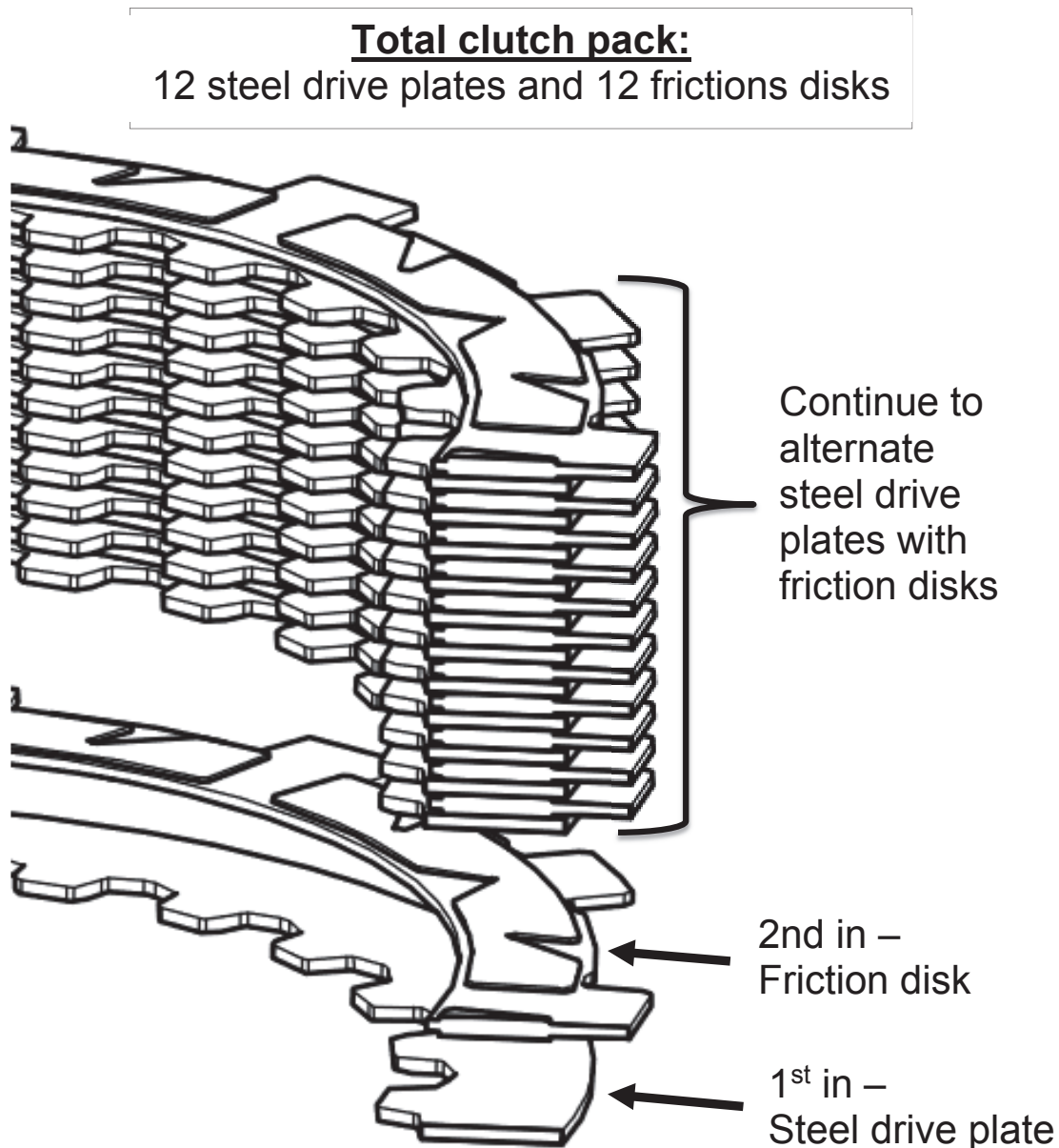

7. After installation, readjust the lever free play.
8. Start the bike and warm it up for a few minutes before riding.
9. Break-in will occur over the first 1-2 hours of riding.



©2017 Rekluse Motor Sports  
Rekluse Motor Sports, Inc.  
[customerservice@rekluse.com](mailto:customerservice@rekluse.com)

# SETUP SHEET 198-7113051

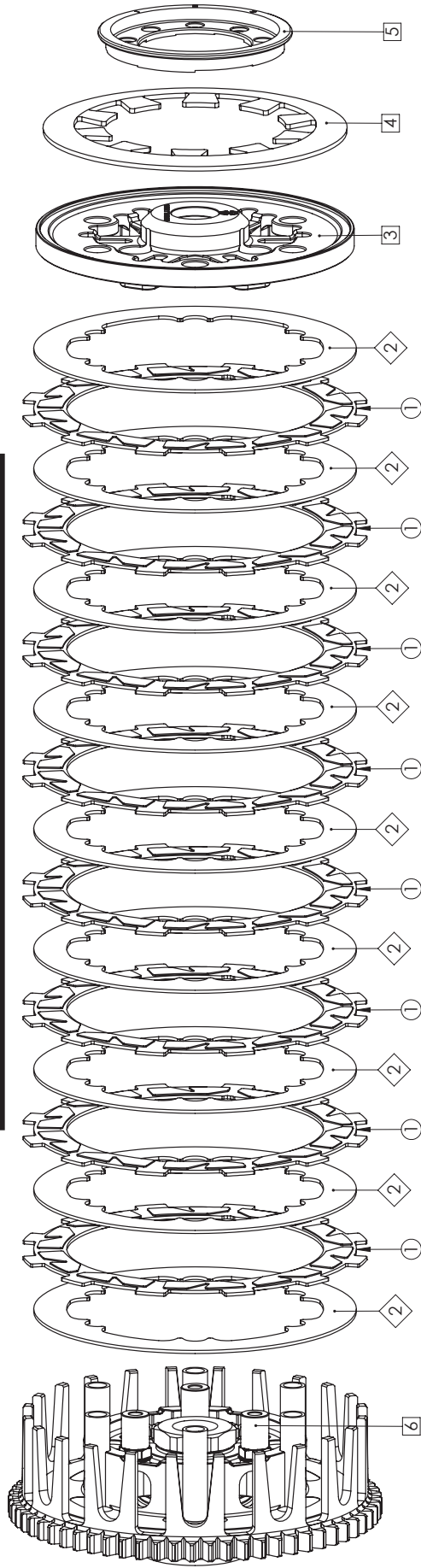

ITEM NO.	DESCRIPTION	QTY.
1	FRICITION DISK	8
2	DRIVE PLATE	9
3	PRESSURE PLATE	1
4	OEM CLUTCH SPRING	1
5	OEM SPRING RING	1
6	CENTER HUB	1

The OEM spring ring has different settings to account for variances in the clutch pack and wear. The optimal setting depends on the thickness of the clutch pack. In general, MORE preload on the spring results in LESS clamping force, which in turn provides a lighter lever pull and less aggressive clutch performance. LESS preload on the other hand provides MORE clamping force, a heavier clutch pull, and more aggressive clutch performance. The OEM spring ring has different settings to account for variances in the clutch pack and wear. Reference the "Spring Ring Optimization Table" for spring ring recommendations.

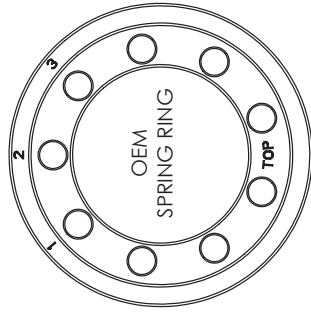

## CLUTCH PACK SPECS & SERVICE LIMITS

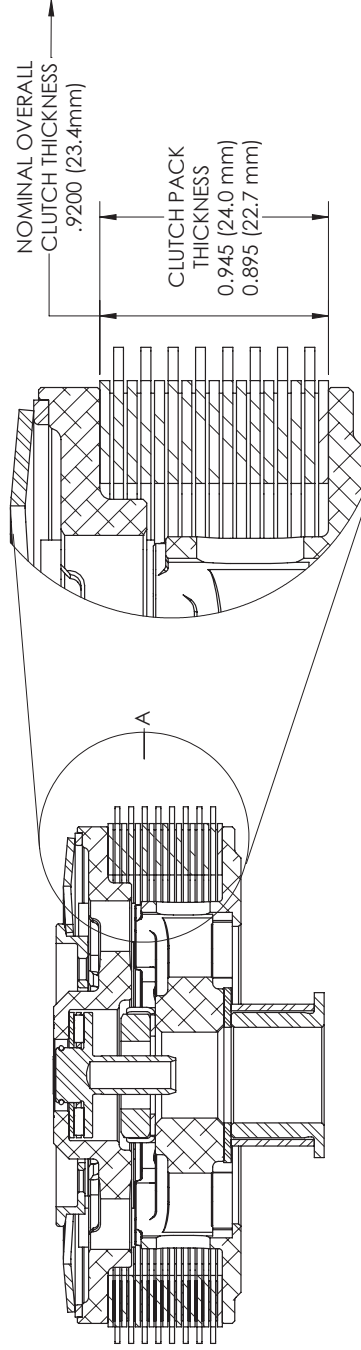

SPRING RING OPTIMIZATION TABLE	
CLUTCH PACK THICKNESS [IN/mm]	SPRING RING SETTING
0.895 - 0.913 (22.7 - 23.2)	3
0.914 - .926 (23.2 - 23.5)	2
>.927 (>23.5)	1