

INSTALLATION GUIDE

1. Soak the friction disks in clean engine oil for 10-15 minutes. Make sure the friction disks are coated on both sides. *Pouring oil into the plastic bag suffices.*

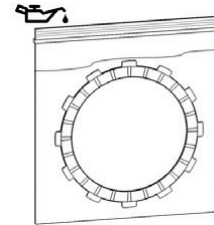

2. Remove the old clutch pack.
3. Remove the old basket sleeves and inspect the clutch basket for damper and/or spring rotational play.
 - Dampers/springs should not be loose. Inspect the clutch basket for notching. Do not install sleeves or use product with a notched basket. Notched basket tang faces can cause the sleeves to break. Do not use baskets that have been filed, machined, or modified on the tangs. Replace basket if necessary.

⚠ WARNING

Failure to inspect the basket and replace if necessary could result in death, serious injury, and/or property damage.

4. Install the new basket sleeves into the basket slots. Make sure the sleeve tabs sit against the inside of the basket, then push the sleeves down until they contact the bottom of the tang slot.

Install all the
basket sleeves

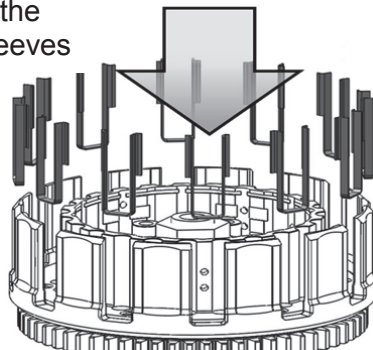

SLEEVE TOP MAY BE
ABOVE OR BELOW
BASKET TANG

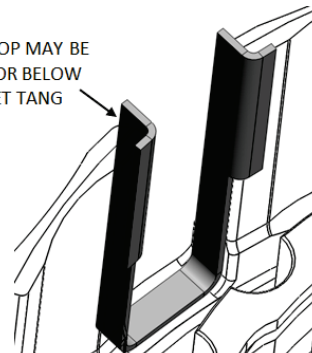

5. Install the clutch pack by **starting with a steel drive plate**.
6. Add a friction disk, then continue to alternate steel drive plates with friction disks for the entire clutch pack, ending with a friction disk.

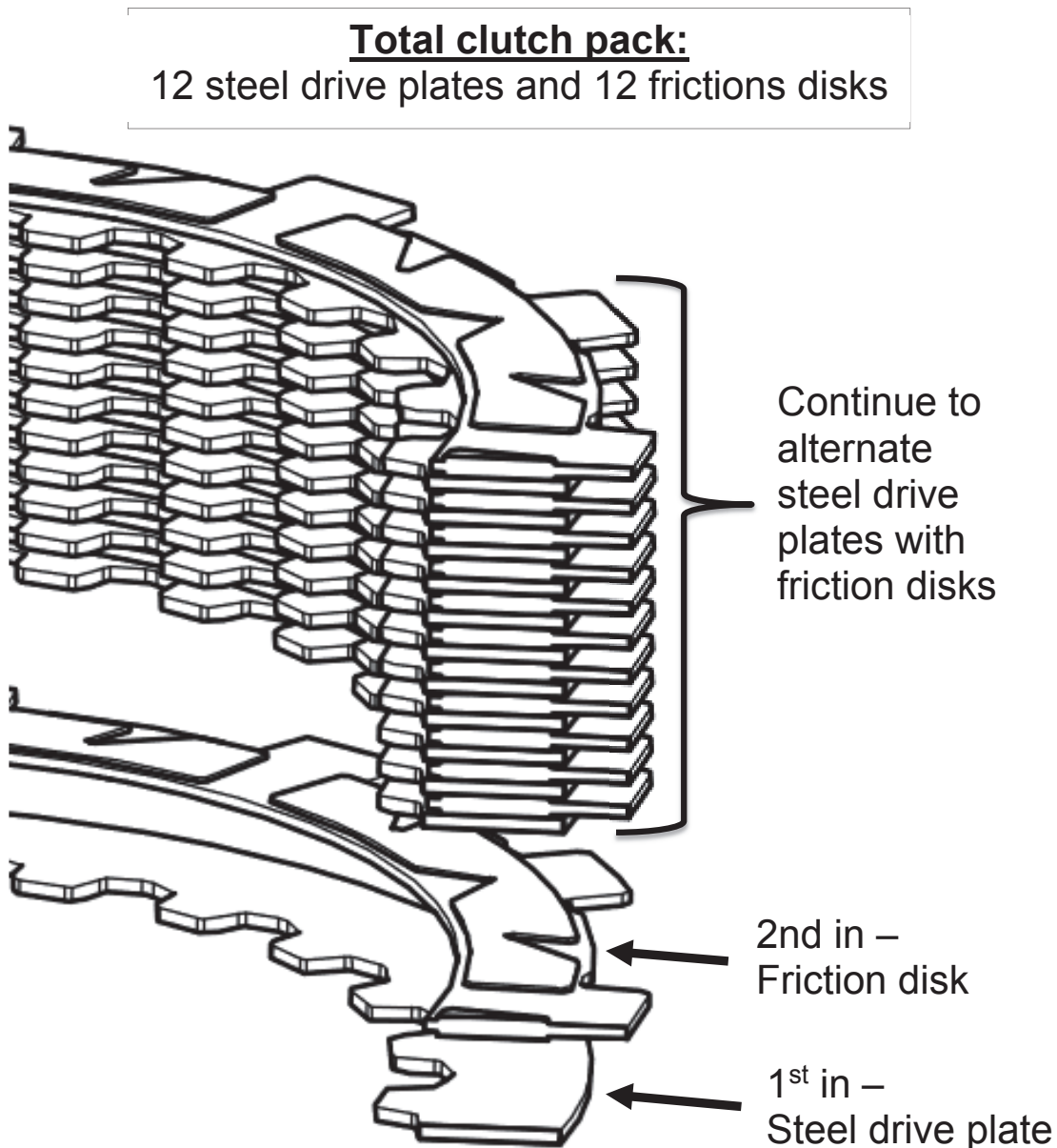

7. After installation, readjust the lever free play.
8. Start the bike and warm it up for a few minutes before riding.
9. Break-in will occur over the first 1-2 hours of riding.



©2017 Rekluse Motor Sports
Rekluse Motor Sports, Inc.
customerservice@rekluse.com